



General Description

8205A uses advanced trench technology to provide excellent $R_{DS(ON)}$, low gate charge and operation with gate voltages as low as 2.5V. This device is suitable for use as a Battery protection or in other Switching application.

Product Summary

- $V_{DS}=16V$
 $R_{DS(ON)}=22\text{ m}\Omega(\text{max.}) @ V_{GS}=4.5V, I_D=1A$
 $R_{DS(ON)}=33\text{ m}\Omega(\text{max.}) @ V_{GS}=2.5V, I_D=1A$
- High Dense Design
- Ultra Low On-Resistance
- Reliable and Rugged

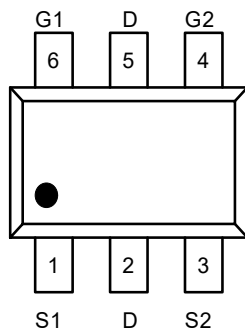

SOT-23-6

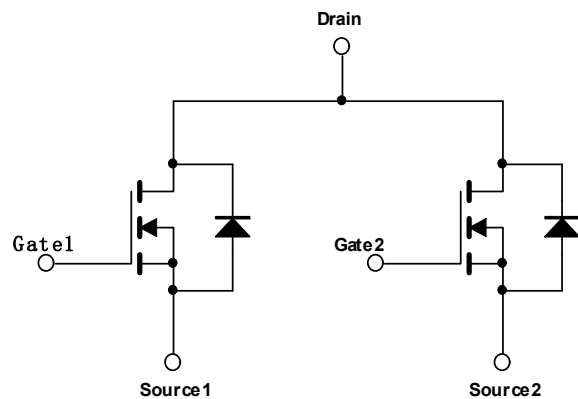

N-Channel MOSFET

Absolute Maximum Ratings $T_A=25^\circ\text{C}$ unless otherwise noted			
Parameter	Symbol	Limit	Unit
Drain-Source Voltage	V_{DS}	16	V
Gate-Source Voltage	V_{GS}	± 12	V
Drain Current-Continuous @ $T_J=25^\circ\text{C}$	I_D	5	A
Pulsed _b	I_{DM}	20	A
Drain-Source Diode Forward Current _a	I_S	2.5	A
Maximum Power Dissipation _a	P_D	1.25	W
Operating Junction and Storage Temperature Range	T_J, T_{STG}	-55 To 150	$^\circ\text{C}$

Notes
Pulse width limited by maximum junction temperature.
Surface Mounted on FR4 Board, $t_s \leq 5$ sec.

Electrical Characteristics (TA=25°C unless otherwise noted)

Parameter	Symbol	Test Condition	Min	Typ	Max	Unit
Static						
Drain-Source Breakdown Voltage	BV_{DSS}	$V_{GS} = 0V, I_D = 250\mu A$	16			V
Drain-Source On-State Resistance	$R_{DS(ON)}$	$V_{GS} = 4.5V, I_D = 1A$		17	22	mΩ
Drain-Source On-State Resistance	$R_{DS(ON)}$	$V_{GS} = 2.5V, I_D = 1A$		23	33	
Gate Threshold Voltage	$V_{GS(th)}$	$V_{GS} = V_{GS}, I_D = 250\mu A$	0.5	0.78	1.0	V
Zero Gate Voltage drain Current	I_{DSS}	$V_{DS} = 16V, V_{GS} = 0V$			1	μA
Gate Body Leakage	I_{GSS}	$V_{GS} = \pm 12V, V_{DS} = 0V$			±100	nA
Forward Transconductance	G_{FS}	$V_{DS} = 5V, I_D = 4A$		9.2		S
Dynamic³						
Total Gate Charge	Q_G	$V_{DS} = 10V,$ $I_D = 4A,$ $V_{GS} = 4.5V$		6.0		nC
Gate-Source Charge	Q_{GS}			2.0		
Gate-Drain Charge	Q_{GD}			2.3		
Tum-On Delay Time	$T_{d(on)}$	$V_{DD} = 10V,$ $I_D = 4A,$ $V_{GS} = 4.5V,$ $R_{GEN} = 25\Omega$		11		ns
Tum-On Rise Time	T_r			23		
Tum-Off Delay Time	$T_{d(off)}$			29		
Tum-Off Fall Time	T_f			8		
Input Capacitance	C_{iss}	$V_{DS} = 8V,$ $V_{GS} = 0V,$ $f = 1.0MHz$		498		pF
Output Capacitance	C_{oss}			89		
Reverse Transfer Capacitance	C_{rss}			67		
Source-Drain Diode						
Max.Diode Forward Current	I_S				1.7	A
Diode Forward Voltage	V_{SD}	$I_S = 1.7A, V_{GS} = 0V$			1.2	V

Notes:

- Surface Mounted on FR4 Board ,T<10 sec ;
- Pulse Test: Pulse Width ≤ 300 μ s, Duty Cycle ≤ 2%.
- Guaranteed by Design, not subject to production testing.

Typical Characteristics (T_J = 25°C Noted)

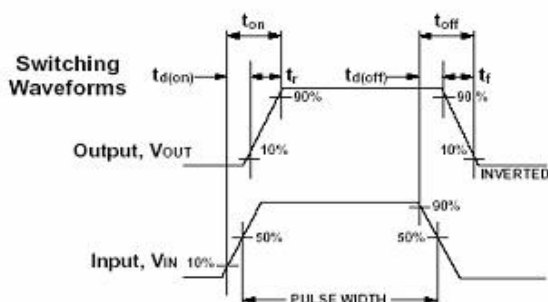
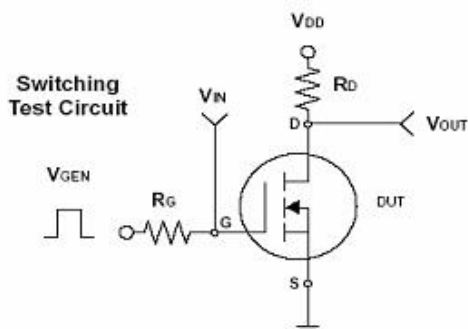
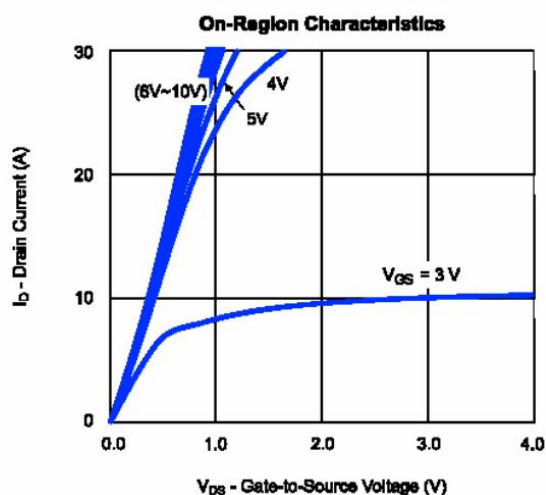
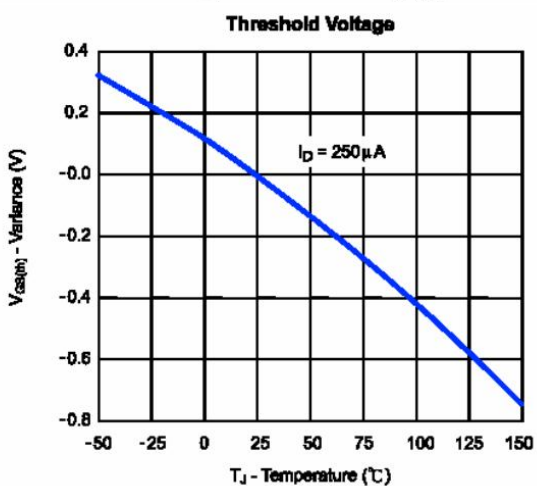
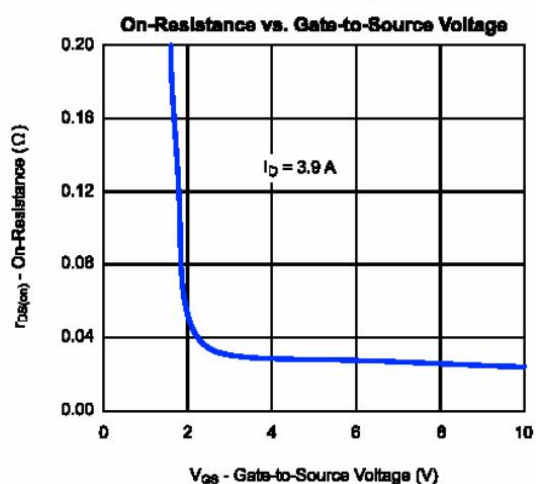
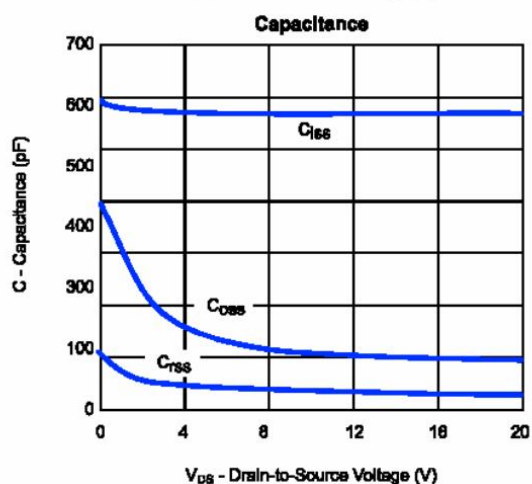
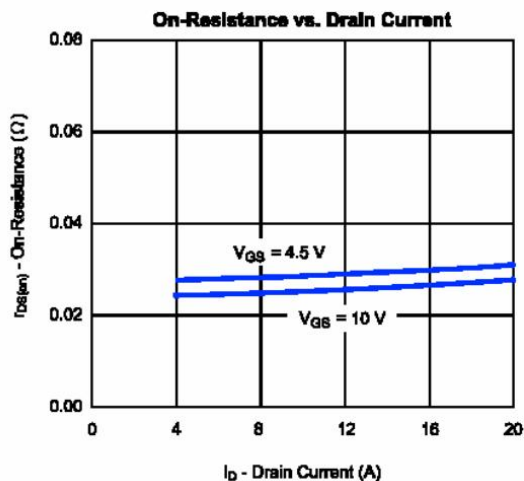
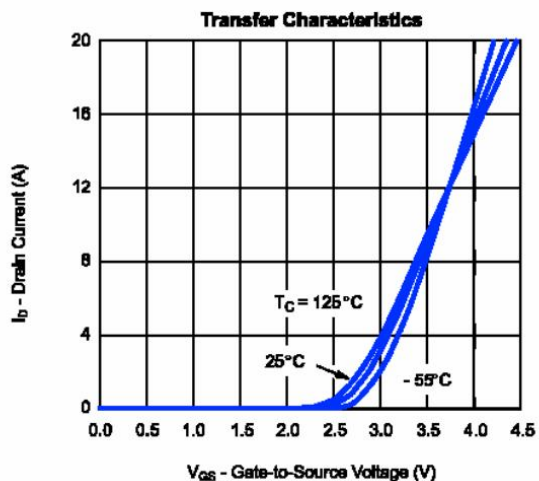

Dongguan hundred power supply technology Co., Ltd.

Package Outline Dimensions

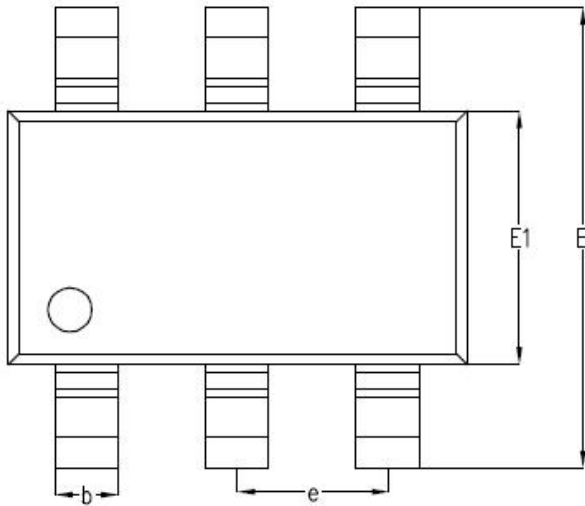
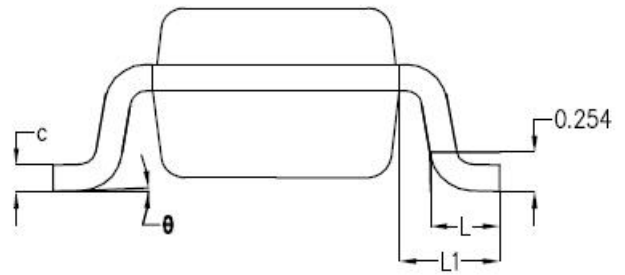
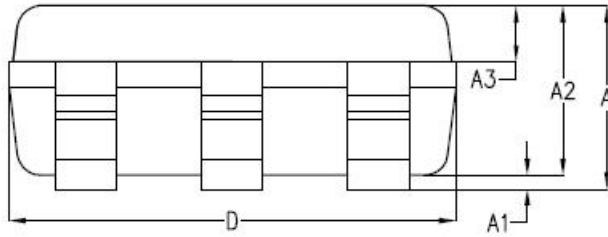

SYMBOL	MILLIMETER		
	MIN	NOM	MAX
A	-	1.19	1.24
A1	-	0.05	0.09
A2	1.05	1.10	1.15
A3	0.31	0.36	0.41
b	0.35	0.40	0.45
c	0.12	0.17	0.22
D	2.85	2.90	2.95
E	2.80	2.90	3.00
E1	1.55	1.60	1.65
e	0.95BSC		
L	0.37	0.45	0.53
L1	0.65BSC		
θ	0°	2°	8°